

**PART NUMBER:** CMS0321KLX

**DESCRIPTION:** speaker

**SPECIFICATIONS**

nominal size	32 x 32 x 14.5 mm		
impedance	8 Ohm $\pm$ 15%	at	1 kHz 1 V
resonant frequency	530 Hz $\pm$ 106 Hz	at	1 V
sound pressure level	80 dB/W $\pm$ 3 dB	1 W	50 cm ave. at 0.6 k, 0.8 k, 1.0 k, 1.2 kHz
response	Fo Hz ~ 20 kHz max 10 dB		
input power	nominal 2 W	handling capacity	4 W
operation	must be normal at program source 2 W		
buzz, rattle, etc.	must be normal at sine wave 4 V		
magnet	size: 18.7 x 4.0 mm		
load test	white noise 2 W	for	24 hours
heat test	65 $\pm$ 2° C	20-50% R.H.	24 hours
humidity test	40 $\pm$ 2° C	90-95% R.H.	24 hours

**FREQUENCY RESPONSE CURVE**

potentiometer range	50 dB
rectifier	RMS
lower limit frequency	20 Hz
wr. speed	100 mm/sec

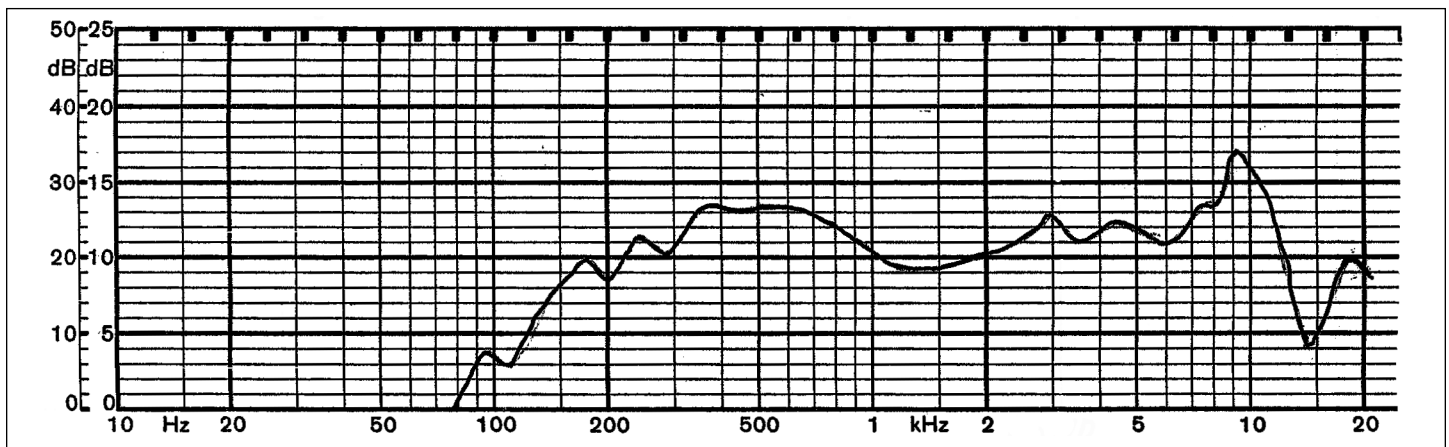

zero level 60 dB

REV.	DESCRIPTION	DATE
A	NEW DRAWING	10/2/2006

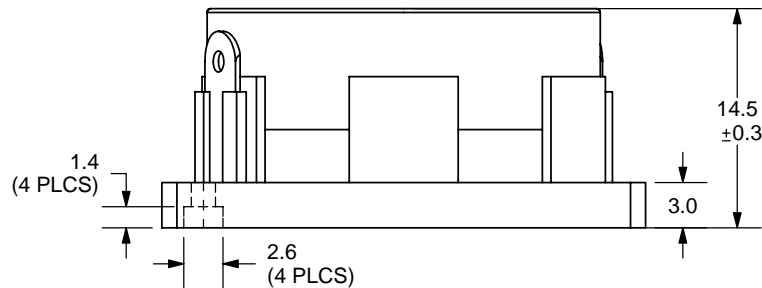
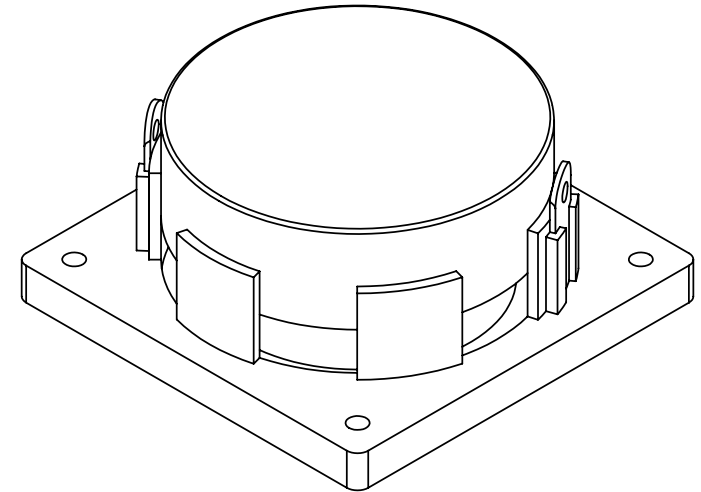
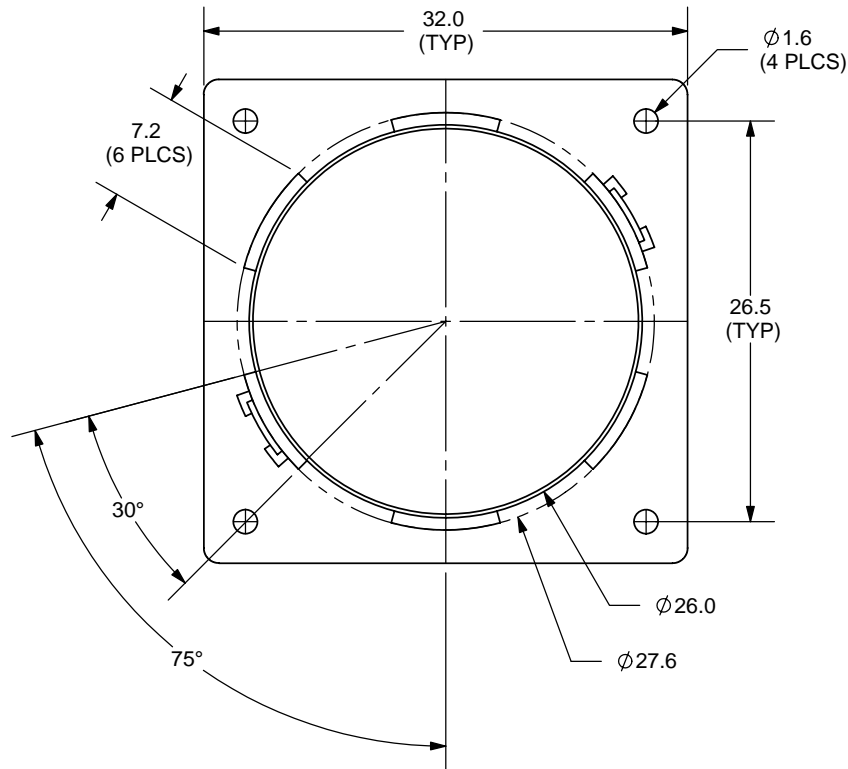

TOLERANCE:  
±0.2mm UNLESS OTHERWISE  
SPECIFIED



20050 SW 112th Ave.  
Tualatin, OR 97062  
Phone: 503-643-4899  
800-275-4899  
Fax: 503-372-1266  
Website: www.cui.com

TITLE: MINIATURE MONITOR SPEAKER		REV: A
PART NO. CMS0321KLX	UNITS: MM [INCHES]	
DRAWN BY: ZRJ	APPROVED BY:	SCALE: 2:1

PC FILE NAME:  
CMS0321KLX

COPYRIGHT 2006 BY CUI INC.